

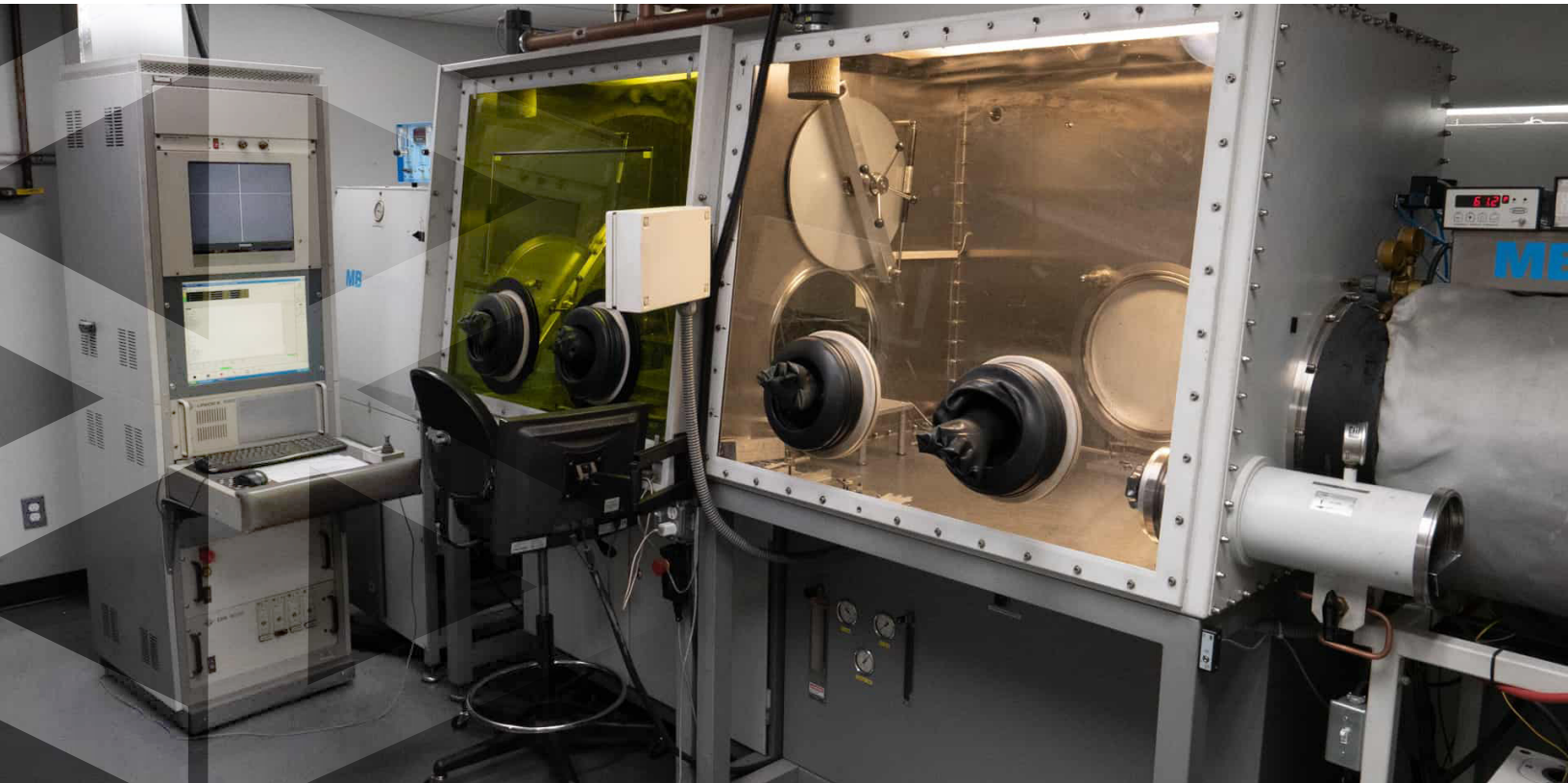

Designer's Guide for Laser Hermetic Sealing

WHITE PAPER



INTRODUCTION

Electronic circuits exposed to corrosive conditions, or required to have extreme performance characteristics, are sealed hermetically into special packages. Epoxy gluing, resistance welding, soldering, electron-beam welding, and laser welding are several of the techniques available for sealing these packages. The disadvantage in the use of epoxies is that they do not create a hermetic seal. Moisture migrates through the epoxy, destroying its hermetic seal.

Resistance seam welding is a reliable process that has been around for many years, but it has several disadvantages. For one, the process requires that the materials to be welded have high electrical resistance, and therefore cannot be used to weld materials such as aluminum or copper. Second, the electrodes must be “run in” on several unwanted packages before production welding begins because new electrodes have a tendency to run hot until they have been burned in. Furthermore, resistance welding can be used only for a lap-weld joint.

Problems develop when solder-sealing is attempted on larger packages. The process requires the whole assembly be heated, and the use of low-melting-temperature alloys may result in the materials not being fully wetted.

Electron-beam welding has many of the same advantages as laser welding, but E-beam systems require vacuum chambers, X-ray shielding, and a fill of inert gas after welding, with another sealing operation by conventional means after that.

Reliability, minimal heat distortion, high processing speeds, a non-contact process, and the flexibility of CNC programming are just a few of the advantages that have pushed laser welding ahead of alternative methods. However, there are several considerations in package design that should be addressed to enable the designer to maximize the unique options lasers provide.

LASER WELDING

First, a short review of a laser system and the welding process. In its simplest form, a laser-welding system consists of a laser, beam delivery and workstation. The Nd:YAG laser is best suited for the welding of electronic packages because its pulsing capabilities can deliver the power to the work piece with minimal heat input. It can also weld reflective materials and tolerate poorer fit—up more than other types of lasers.

The laser beam can be delivered to the workstation by standard optics or through a fiber-optic beam delivery (FOBD). When standard optics are used, the laser is typically positioned on top of the workstation and a mirror angled at 45 degrees directs the beam downward through the focusing lens to the work piece. A FOBD uses a flexible, optical cable to deliver the beam to the workstation allowing the laser to be remotely located away from the processing area. Time-sharing or energy-sharing fiber systems permit the output of one laser to be used at several workstations.

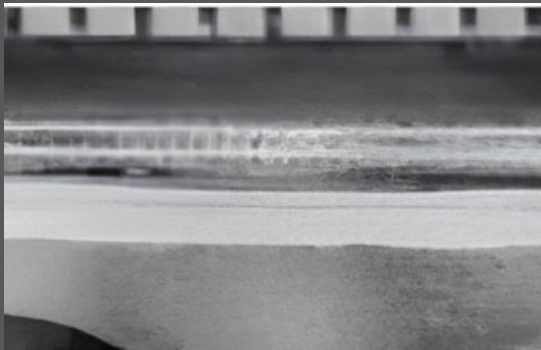

Figure 1a, top weld on a stainless steel relay.



Figure 1b, cross-section of a butt weld in the stainless-steel relay in figure 1a, weld penetration is 0.008"

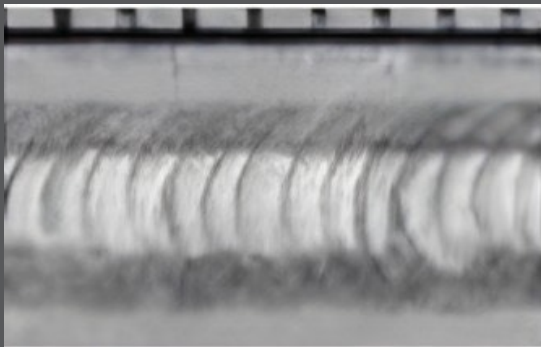

Figure 1c, top view of a 4047-to-6061 aluminum butt weld.



Figure 1d, weld cross-section of drop-in cover shown in figure 1c. The cover is 0.02" thick 4047 aluminum and the housing is 6061 aluminum. Weld penetration is 0.47".



In either case, a closed-circuit television-viewing system is necessary. The camera looks directly down the beam-delivery path. Cross-hairs are electronically generated on the TV screen and centered where the focused laser beam strikes the work piece. The focused spot then can be exactly positioned for the weld by moving the part so that the TV image of the seam is aligned with the cross-hairs. The CNC controls motion of the part under the beam, as well as all process functions. This includes laser parameters, shutter controls, and shield-gas delivery. Programs for each type of part to be welded can be stored in the CNC, with little or no adjustments in the set-up.

A glove-box system is an enclosed workstation that can be sealed from the outside atmosphere while its interior is evacuated and filled with a purified, inert-gas mixture. Parts are loaded through a two-way isolated transfer chamber, where they are prepared for welding and manipulated through to a similarly isolated weld chamber by outside operators using sets of gas-tight gloves.

HOW THE LASER WELDS

When the laser energy is absorbed by the material, heat is conducted into the material, creating a weld pool in a very localized area. No filler material is needed, but a tight fit-up of the parts is essential.

Figures 1a through 1h show top views and cross-sections of welds in various electronic packages. Typical weld penetrations can be adjusted within a range from 0.01 to 0.06", depending on the configuration of the package joint. The heat input to the part is kept to a minimum because of the laser's ability to deliver the power in precise locations. Depending on the type of material, some heat is conducted through the part from the weld zone, but the losses are minimal. Reflection losses also occur, especially in materials such as aluminum, copper and gold. Initial reflection loss is high, but the first part of the laser pulse melts the surface and absorption by this molten material can be up to 20 times greater than absorption by the solid state. The welding is typically performed in an inert atmosphere, usually consisting of a mixture that is



Figure 1e, top view of nickel-and gold-plated Kovar butt weld.



Figure 1f, weld cross-section of drop-in cover shown in figure 1e. Weld penetration is 0.025".



Figure 1g, weld cross-section of 4047-to-6061 aluminum fillet weld. The cover is 0.022" thick 4047 aluminum and the housing is 6061 aluminum. Weld penetration is 0.038".

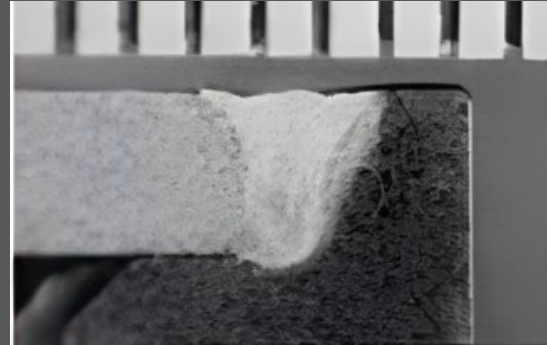

Figure 1h, weld cross-section of Beryllium-copper-to-copper butt weld. Weld penetration is 0.055".

90 percent nitrogen and 10 percent helium, with less than 100 PPM of moisture and oxygen. This keeps the weld free of contaminants. Because the inert atmosphere is contained within the package, the helium can be used as a tracer gas for leak detection, eliminating post-weld "bombing". A slow-flow cover-gas also should be supplied through the beam-delivery nozzle, or through a side jet, to keep debris from being deposited on the focusing lens.

JOINT CONSIDERATIONS

There are three possible types of laser weld—butt, lap, and fillet—each with its associated joint configuration. Figures 2a through 2e show the geometry of each of these joint types.

A butt weld design is typically used for larger housings. Tolerances must be held tight for the lid to fit properly in place, which can increase package cost. However, no special tooling is required to hold the lid in position. Since this laser-welding process usually does not use any filler material, the fit-up of the lid to package is critical in order to ensure a hermetic seal. If the gap is too large, the materials may not flow together to make the weld joint.

Figure 2a shows a butt weld with the dimensions necessary for the cover to drop into the housing. The cover and housing dimensions have tolerances that will ensure the lids drop easily into the housing and the gap is kept to a minimum. The lip on which the cover rests has a minimum width of 0.03" and the edge around the lip is typically 0.006".

Sometimes a ribbon strip is used as an intermediate filler material when welding aluminum. The need for this strip will be examined later in a discussion of material

considerations. Using the drop-in cover method, the lid is reduced in size to add the filler material. The filler thickness can range from 0.005 to 0.015", as shown in figure 2b.

A lap weld is less expensive to produce in terms of machine tolerances, but some tooling is required to align the cover. Because the lid is not required to fit in a precise area, and because the weld does not follow a seam, the lid-size tolerances can be up to ± 0.01 ". Fit-up is determined by the flatness of the lid, which should be within 0.002 to 0.004"—less for welds thinner than 0.02". A ribbon strip also can be used when lap welding aluminum. Figure 2d shows the geometry of this package in which the ribbon is sandwiched between the lid and the housing. Because the weld must have greater penetration, higher laser-pulse energies are needed.

The last fillet weld, shown in figures 2e and 2f, is the one most commonly used for electronic package sealing. Tooling is necessary to align the lid, and position tolerances should be ± 0.002 " for repeatable contour programming.

The lid should cover the housing by twice the thickness of the lid and leave at least the same amount of housing exposed from the edge of the lid to the package edge.

MATERIAL CONSIDERATIONS

The metallurgy of laser welding is not much different than other welding techniques, but there are two special attributes that must remain in the designer's mind. The first attribute is that laser welding is almost always an autogenous process, which means that unlike GMA welding, no metal is added during the process. This was discussed previously in considerations of fit-up tolerances. The second special attribute of laser welding is the relatively rapid cooling rate of the solidifying metal, which places some special constraints on a few metal choices.

When a designer requires a lightweight, corrosion-resistant, heat-dissipating, robust, and economical package, aluminum is usually the first choice. Aerospace packages for microwave circuits, sensor mounts, or small-ordnance initiators are the most common examples of aluminum components that can be laser welded. Laser welding with penetrations up to 1.5mm are common in aluminum alloys. The high reflectivity and conductivity of aluminum requires higher-peak-power pulses than are needed for ferrous alloys, but standard Nd:YAG lasers easily produce these powerful pulses.

Type 6061-T6 is the material of choice because of economics, rigidity, and ease of machining. However, the material cannot be successfully laser welded to itself, because the partially solidified melt zone cannot withstand the stress of shrinkage upon solidifying and cracks are formed (termed "solidification-cracking" or "hot cracking"). The solution to this problem is to improve the ductility of the weld metal by using an aluminum with high silicon-content, such as alloy 4047 (Al-12 percent Si). This alloy is very ductile as a solid and difficult to machine into complex shapes. Therefore, 6061 is usually employed as the package component with intricate features, and 4047 is used as a simple lid that is relatively thin (typically less than 1 mm). A 4047 ribbon can be inserted between 6061 components to produce excellent welds (see figure 2b), but this requires a very labor-intensive step, unless round washers or other simple, preform geometries can be employed.

Alloy 2219 and many other popular aluminum alloys are also weldable using 4047 filler metal. So far, there has been no experience indicating that 2219 can be welded to itself without the use of 4047 filler, as has been reported

elsewhere.¹ The only aluminum alloys that can be welded with low heat input and without the use of 4047 filler are the 1000 and 1100 alloys.

These commercially-pure aluminum alloys have the metallurgical characteristics to avoid hot cracking, but their poor mechanical and machining properties usually prohibit use in most applications.

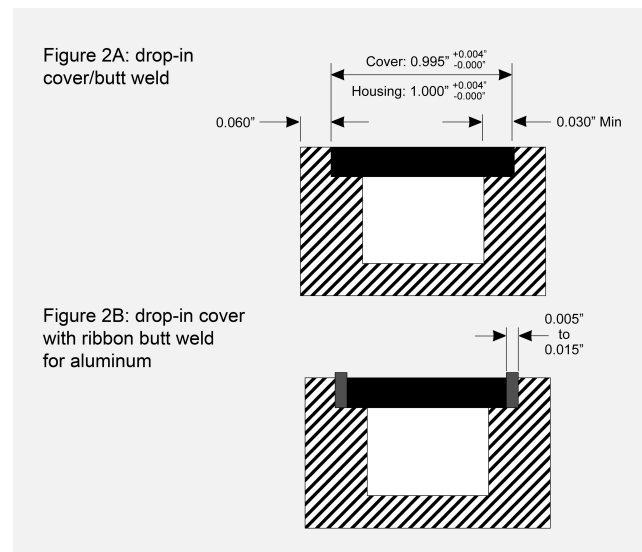

Kovar (Fe-29 percent Ni, 17 percent Co) is typically chosen as a package material because its thermal-expansion coefficient matches that of other package constituents such as glass-to-metal seals. Plated Kovar offers good corrosion resistance and can be machined and drawn relatively easily. Kovar is denser and heavier than aluminum, but it presents few metallurgical problems compared to those of aluminum. In addition, it provides the benefit of a low coefficient of thermal expansion. Usually welded to itself, Kovar welds with ease up to 2 mm penetration. It is important to consider plating constituents when specifying Kovar package components.

Stainless steel provides excellent corrosion resistance and good metallurgical characteristics useful for a hermetic package. Stainless steel is slightly more difficult to machine, and is heavier and more expensive than aluminum. Some aerospace packages employ stainless steel, but the majority of uses seem to be in the military, the medical field, or in automotive airbag systems.

The austenitic stainless steels (AISI-300-series alloys) have high nickel contents that are beneficial for laser welding. Types AISI-301, 304, 304L, 316, and 318 are the most popular choices for electronic packaging, with 304L and 316 the leading candidates. Although these grades of stainless steel generally produce hermetic laser welds, specific metallurgical compositions of alloys such as 304L are susceptible to cracking. Once encountered, entire lots of a grade of stainless steel can produce cracking. This can be avoided by specifying the specific composition of the lot and verifying with weld tests.

Because of their high sulfur and high phosphorous content, free-machining stainless steels, such as AISI-303, should be avoided when welding is required. These elements segregate to the weld center line, causing a brittle zone that cracks under the stress of solidification (hot cracking). Type 303 can sometimes be welded to another 300-series alloy, but different lots of 303 can have inconsistent welding characteristics.

The ferritic stainless steels (400-series alloys) are generally not good candidates for laser welding, because the high cooling rates of laser welding cause martensitic formation in the weld zone. This brittle martensite can crack under solidification-shrinkage stress or in service. Pre-heating can reduce martensite formation in 400-series alloys. Some 400-series alloys can be welded to 300-series alloys with good results, but again, results can vary from batch-to-batch, or with variations in heat input. Stainless steel can easily be welded to 2 mm penetration.

Fe-Ni alloys, such as Alloy 42 or Mu-Metal, are usually chosen for the electrical or electromagnetic characteristics. Alloy 42 has good electrical conductivity and is sometimes used as a replacement for brass. Mu-Metal has the correct magnetic properties for gyroscope guidance and similar components. Invar is used in fiber communications assemblies or any other package that requires a near-zero coefficient of thermal expansion near room temperature. All of these materials weld well and have laser welding characteristics that are similar to those of Kovar.

Titanium is chosen for its biocompatibility in pacemaker and pacemaker battery packages. Commercially-pure titanium and Ti3Al4V weld extremely well, but nitrogen cannot be used as a cover gas because of the formation of titanium nitride. Argon or helium must be used to prevent oxidation. Zircalloy is another excellent material for laser welding. Nuclear applications are the main use of zircalloy.

“Titanium is chosen for its biocompatibility in pacemaker and pacemaker battery packages”

Both titanium and zircalloy have similar welding characteristics and penetration to 2mm is easily achieved.

Copper alloys are used in hermetic packages where electrical and thermal conductivity are important or where its non-magnetism is important. Pure copper has good metallurgy for welding, but it is highly reflective to Nd:YAG laser energy and has high thermal conductivity, therefore making it difficult to achieve weld penetrations greater than 0.5 mm. The reflectivity of pure copper can be overcome by plating it with electroless nickel before welding. Beryllium copper (Be Cu) has better weldability and can produce very good welds to pure copper.

Copper-tungsten is very heavy, but has very good heat conductivity, as well as a thermal expansion close to that of many electrical components. Copper-tungsten and copper-nickel alloys weld well. Brass alloys are not good candidates because of their zinc constituents. Zinc vaporizes near the melting temperature of other metals, and vapor expansion tends to expel metal out of the weld pool. The little molten metal remaining solidifies, trapping the gas pockets in the joint and creating porosity.

Platinum, silver, and gold are weldable but with penetration limited to less than 0.5 mm because of high reflectivity and thermal conductivity. These metals are used for special applications in aerospace, electronics, and military ordinance, where corrosion resistance and electrical conductivity are paramount.

To summarize the metallurgical considerations for laser welding, most metals used for electronics packaging can be welded with a Nd:YAG laser. Low heat input is a key feature for heat-sensitive components that require weld penetrations typically less than 2mm. Within each metal group, there are alloys that have better weldability than others and, in some cases, there are compositions of alloys that cannot be welded. In general, care in the selection and control of package materials provides high-quality, crack-free, hermetic welds.

PLATING CONSIDERATIONS

Many hermetic packages employ platings to improve corrosion resistance, solderability, or for better absorption of the laser energy. Nickel and gold are the most common plating choices. Nickel is used alone, and it is almost always used as an under-plating for gold or tin. These metals are plated on top of the nickel, because they do not plate well directly to other base metals.

Nickel can be plated by an electrolytic or electroless process. Ferrous alloys such as Kovar and stainless steel must be plated with electrolytic nickel. Electroless nickel plating contains phosphorous, which produces intermetallics within the weld that cause porosity and cracking. Gold-plated Kovar packages weld well, as long as there is an under-plating of electroplated nickel. Gold-plated mild steel produces weld voids due to intermetallic segregation in the weld. Aluminum and copper can benefit from nickel plating, because the plating has better laser-energy absorbability than the base metals. This technique is not often used with aluminum but is an excellent aid in the welding of copper and its alloys.

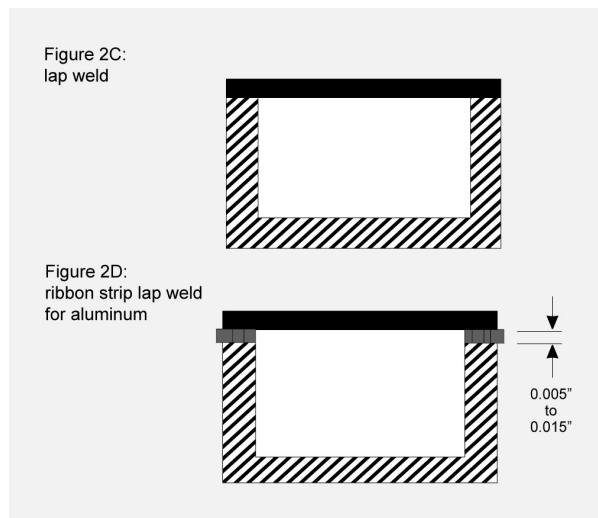

Tin and zinc have low melting and vaporization points, which result in porous welds. These platings should be absent from the weld joint.

Even when platings beneficial to laser welding are chosen there are other plating additives, such as organic brighteners that can cause problems. Organic brighteners are gaseous when metals are liquid and, as discussed before, they create voids in the weld. Matte finishes with no organic brighteners work best for improving laser welding performance.

If platings are used that are not compatible with laser sealing, they must not be present in the weld joint. Masking the weld area before plating or machining away the plating before welding are methods used to accomplish this. Platings that only exist on top and not in the joint are often vaporized by the impinging laser beam and will not affect the weld quality. In all cases, it is wise to specify the correct platings, perform trials with the components before finalizing the designs and continuously monitor the components and process with data on all batches and lots of materials.

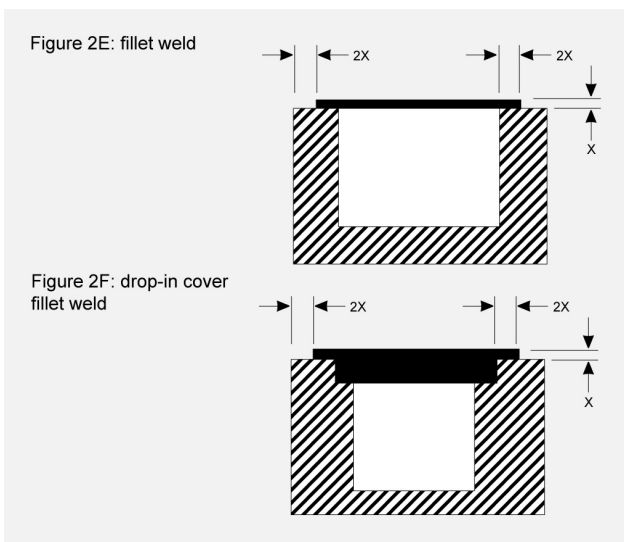

THE WELDING PROCESS

The hermetic-sealing process begins by placing the parts in a vacuum bake-out oven to remove moisture. The parts are typically baked for 24 hours at 125 C. Since it is a long process, more than one oven may be needed to fully utilize the laser's capabilities. When the baking cycle has been completed the chamber is filled with an inert atmosphere. The parts can now be transferred to the glove-box for further assembly or immediate laser welding.

The parts are loaded into a secure and accurate welding fixture and the corresponding program is activated in the CNC. The fixture can be a tray that will hold a number of parts. This will save time since the filling of the chambers in order to transfer parts can be time-consuming. Complex parts usually need to be tack-welded before the seam welding can be performed. Tack welding will hold the lid in position during the seam welding cycle. The welding cycle can last

from a few seconds to a few minutes, depending on the length of the weld and the number of parts being welded.

After the welding, the parts are removed from the glove-box. If rework must be done on a package, the weld is simply machined out and the lid is removed. Repair can then be done on the module and a new lid welded in place. In some cases, the package can be designed for the entire weld to be removed. Then, an oversized lid is needed for re-sealing.

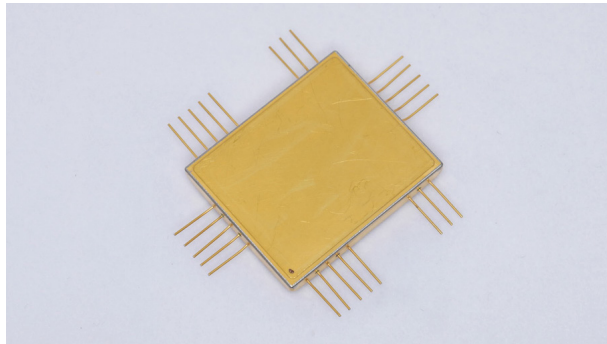

A completed, laser hermetically sealed assembly.

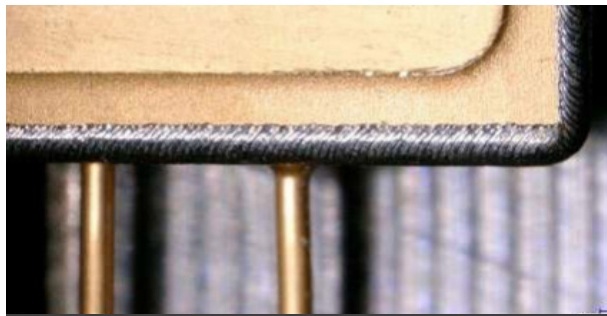

40x magnification of the finished weld.

CONCLUSION

The laser welding process allows designers to expand upon the types of joints, materials, and platings possible for their products. These options, along with speed, reliability, flexibility, and many other advantages, have earned and will continue to earn laser welding its position as the leading technology for hermetic sealing of electronic packages.

ABOUT EB INDUSTRIES

EB Industries delivers on-time precision welding solutions that exceed expectations for quality, technical innovation and customer service.

If you're looking for the best precision welding technology, trust in EB Industries for electron beam or laser welding solutions. With six decades of pioneering welding technology, we consistently deliver precision welding, cutting and processing services designed to make your work easier and schedules tied to when you need it, not when we can do it.

EB Industries offers a wide variety of capabilities that when taken together no one else in the market provides. We offer the advanced technical expertise to solve even the most difficult welding challenges and materials even on exotic materials: titanium, molybdenum, beryllium or dissimilar metals together such as copper to stainless steel.

Our certifications offer the assurance of dependable weld quality, including certifications to AS9100D, ISO 9001:2015, ISO 13485 as well as NADCAP certification for welding.

Find out why we achieved a perfect 100 Net Promoter Score, based on our commitment to the four pillars of the EB Pledge: Trusted Partnerships, Accountability, Technical Innovation and Expertise and Service and Support. Learn more at www.ebindustries.com.

AUTHORS

Sharon Gorscak, Harald N. Bransch, Thomas R. Kugler
Lumonics Corp., Industrial Products Division, Livonia, Michigan

REFERENCES

1. G Simpson, Laser-Welding the Large MIC; A New Approach to Hermetic Sealing, *Microwave Journal*, November 1984.
2. G. Pacary, M. Moline, and J. Lipold, A Diagram for Predicting the Weld-Solidification-Cracking Susceptibility of Pulsed-Laser Welds in Austenitic Stainless Steels, *Edison Welding Institute Research Brief No. B9008*, September 1990.
3. N.R. Stockham and C.J. Dawes, Resistance Seam and Laser Welding of Large Hybrid Metal Packages, *International Journal of Hybrid Microelectronics*, October 1983.
4. C.M Bosnos, Laser Welding Systems for Hermetic Sealing, Proceedings of SPIE – *The International Society for Optical Engineering*, Volume 668, Quebec City, Canada June 3-6, 1986.
5. C.J. Maryatt, Production Package Sealing, Lasers in Electronics Manufacturing Conference, *Society of Manufacturing Engineers*, December 1-2, 1988.

Contact authors at Lumonics Industrial Products Division, 19776 Haggerty Road, Livonia, MI 48152-1016, telephone (313)591-0101.